

ELGi AIRMATE AIR ACCESSORIES

Total Compressed
Aircare Solutions

Air Quality and Energy Saving

ELGi[®]
Always Better.



COMPRESSED AIR SOLUTIONS FOR ALL SUSTAINABLE AIR NEEDS



OIL FREE SERIES SCREW
45 - 450 kW | 190 - 2601 cfm



EG SERIES ROTARY SCREW
11 - 250 kW | 45 - 1540 cfm



EN SERIES ROTARY SCREW
2.2 - 37 kW | 8.0 - 249 cfm



PISTON COMPRESSOR
5.0 - 30 HP | 15 - 98 cfm

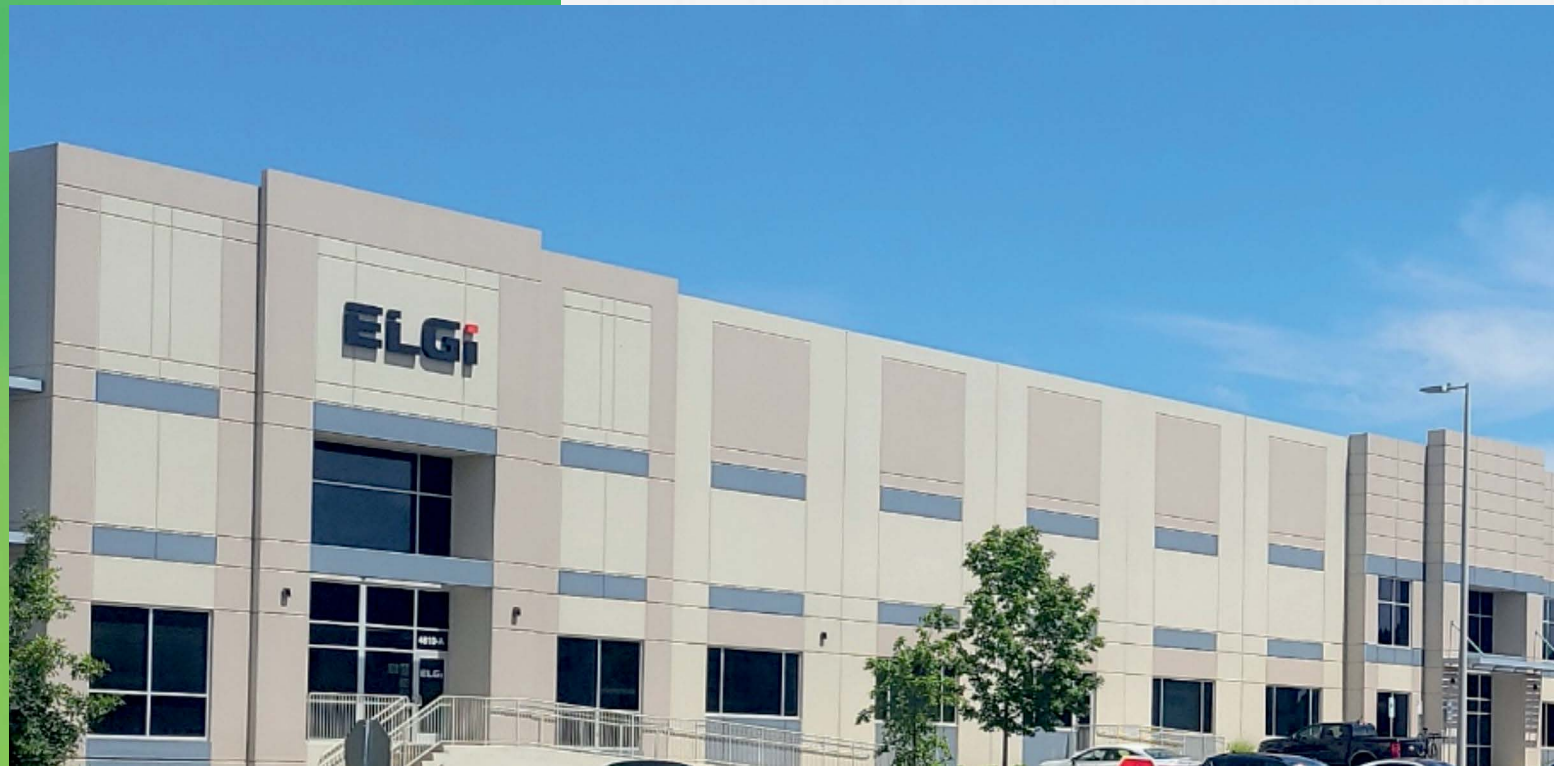

With the Conserve Energy Saving Accessories and Airmate Downstream Accessories, ELGi is Striving for a Clean, Greener, and Sustainable Future.

PREVENT REAL LIFE PROBLEMS WITH ELGi AiRMATE REFRIGERATION AIR DRYERS AND FILTERS



Real-Life Problem 1
Unwanted Abrasive Sludge



Real-Life Problem 2
Corrosion of Piping



Real-Life Problem 3
Damaged Pneumatic Tools

Why do we need to dry the air?

When atmospheric air cools down, following a compressor compression process, water vapor precipitates as condensate. This is the form of water that is naturally present in the air we breathe. Under average conditions, a compressor with a capacity of 106 cfm at 108 psi will generate approximately 10.5 gal of water per day. This condensate must be removed from the compressed air system to prevent corrosion and damage to transmission piping and end-use machines. Compressed air drying is hence essential and is an important part of the air treatment process.

Why do we need to filter the air?

Why do we need to filter the air? Compressed air will also contain water, dirt, wear particles, bacteria, and even degraded lubricating oil. All these impurities mix to form an abrasive sludge. This sludge is often acidic and accelerates wear and tear of tools, pneumatic machinery, block valves, and orifices. This results in expensive air leaks and high maintenance. It also corrodes pipes and can bring the production process to a standstill.

Only compressed air that is completely clean and dry will ensure reliable working of compressed air systems and maximum savings. The favored method of drying the compressed air is through refrigeration dryers and filtering through the downstream filter. ELGi offers a reliable solution through ELGi Airmate Refrigerant Air Dryers and Filters. The dryers ensure longer life of compressed air systems through the efficient removal of the condensate and contaminants through filters.

TOTAL AIR CURE SOLUTIONS FOR CLEAN AND DRY AIR

1 Ambient air of 106 cfm at 95 °F with 60% RH contains 21.6 gal of water / day



2 Compression ratio 1:10 working volume of 10.5 cfm at 113 °F will precipitate 16.1 gal of water/day & get removed by the moisture separator

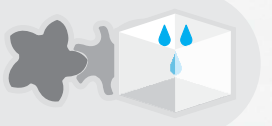

3 ELGi Airmate Refrigerant Dryer will remove 5.0 to 5.3 gal of water/day

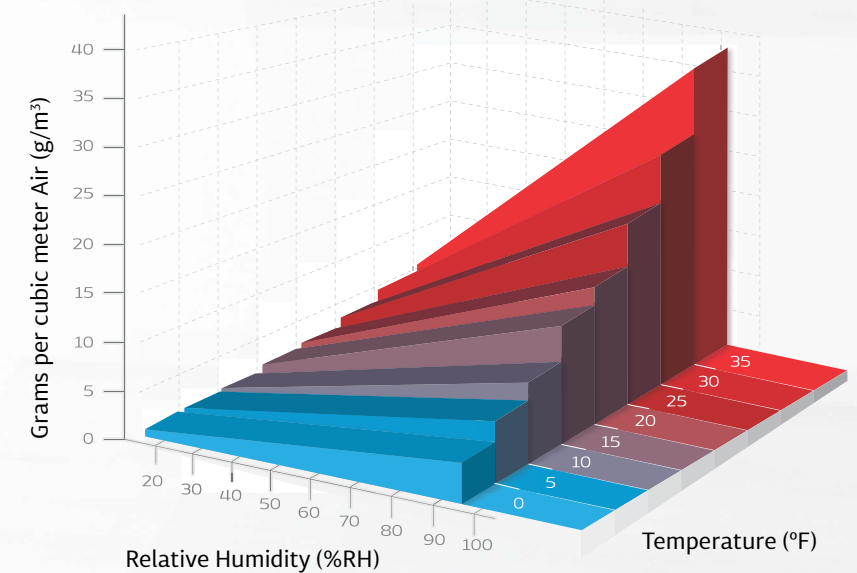



EGRD REFRIGERANT DRYER

ELGi Global Refrigerated Dryer (EGRD) is suitable for all applications which require constant dew point. EGRD series dryers provide the customers with the best overall value proposition and excellent performance.

The dryer is manufactured in compliance with applicable international standards (UL, CE, CRN) and designed according to international quality standards.

OVERALL VALUE PROPOSITION



LOWEST PRESSURE DROP



LOWEST SPECIFIC POWER CONSUMPTION

OZONE-FRIENDLY REFRIGERANT

ELGi always strives to deliver products and solutions to make the earth and the environment safer and a better place to live. As per international protocol, ELGi uses ozone-friendly R 134 A and R 407 C gas as the refrigerant, which has zero ozone-depletion potential.



TECHNICAL SPECIFICATIONS

Model	Inlet flow capacity	Max. working pressure	Nominal power consumption in HP	Compressed air connections	Cooling media	Dimensions (inch)			Gross weight in lbs
	scfm	psi	Air cooled			Length	Width	Height	Air cooled
Single phase / 115 V / 60 Hz									
EGRD10	10	232	0.1	3/8" NPT	Air	12.1	14.5	17.1	46
EGRD15	15	232	0.2	3/8" NPT	Air	12.1	14.5	17.1	48
EGRD20	20	232	0.2	1/2" NPT	Air	15.5	20.2	19.6	55
EGRD30	35	232	0.2	1/2" NPT	Air	15.5	20.2	19.6	62
EGRD40	50	232	0.3	1/2" NPT	Air	15.5	20.2	19.6	70
EGRD50	65	232	0.3	1/2" NPT	Air	15.5	20.2	19.6	74
EGRD80	75	203	0.4	1" NPT	Air	14.9	16.5	30.5	75
EGRD100	100	203	0.7	1-1/4" NPT	Air	14.9	17.5	30.5	86
EGRD150	125	203	1	1-1/4" NPT	Air	14.9	17.5	30.5	88
EGRD175	150	203	1	1-1/4" NPT	Air	20.5	17.9	34	90
EGRD200	175	203	1.1	1-1/2" NPT	Air	23.8	22.8	37	119
Single phase / 230 V / 60 Hz									
EGRD150	125	203	1	1-1/4" NPT	Air	14.9	17.5	30.5	88
EGRD175	175	203	1.1	1-1/4" NPT	Air	20.5	17.9	34	90
EGRD200	200	203	1.2	1-1/2" NPT	Air	23.8	22.8	37	119
EGRD250	220	203	1.2	1-1/2" NPT	Air	23.8	22.8	37	123
EGRD300	300	203	1.5	2" NPT	Air	24	24.6	40.5	207
EGRD400	375	203	2.2	2" NPT	Air	24	24.6	40.5	212
EGRD500	480	203	2.3	2-1/2" NPT	Air	28.1	28.5	45.5	317
Three phase / 460 V / 60 Hz									
EGRD200	175	203	1.2	1-1/2" NPT	Air	22.8	21.8	37	159
EGRD250	220	203	1.3	1-1/2" NPT	Air	22.8	21.8	37	176
EGRD300	300	203	1.4	2" NPT	Air	24.6	21.8	38.3	238
EGRD400	375	203	2.7	2-1/2" NPT	Air	28.5	26.1	43.5	353
EGRD500	480	203	2.9	2-1/2" NPT	Air	28.5	26.1	43.5	375
EGRD600	600	203	2.6	ANSI 3" #150	Air/water	35.1	39.3	65.6	529
EGRD750	800	203	3.2	ANSI 3" #150	Air/water	35.1	39.3	65.6	534
EGRD900	900	203	3.9	ANSI 3" #150	Air/water	35.1	39.3	65.6	606
EGRD1100	1000	203	4.6	ANSI 3" #150	Air/water	35.1	39.3	65.6	608
EGRD1254	1250	203	5.6	ANSI 3" #150	Air/water	35.1	39.3	65.6	686
EGRD1552	1500	203	6.4	ANSI 4" #150	Air/water	44.6	49.8	68.8	1,021
EGRD1750	1750	203	7.5	ANSI 4" #150	Air/water	44.6	49.8	68.8	1,186
EGRD2000	2000	203	8.6	ANSI 4" #150	Air/water	44.6	49.8	68.8	1,190
EGRD2900	2500	203	9.8	ANSI 4" #150	Air/water	44.6	49.8	68.8	1,349
EGRD3000	3000	203	12.2	ANSI 6" #150	Air/water	51.1	71.2	71.2	1,830
EGRD4000	4000	203	15.7	ANSI 8" #150	Air/water	55.1	89	73.6	2,330
EGRD5000	5000	203	23.5	ANSI 8" #150	Air/water	55.1	89	73.6	2,650
EGRD6000	6000	203	25.5	ANSI 8" #150	Air/water	60.8	88.3	96	3,640
EGRD7500	7500	203	27.1	ANSI 8" #150	Air/water	60.8	88.3	96	4,030
EGRD8000	8000	203	35	ANSI 10" #150	Air/water	61.9	111.3	96.6	4,730
EGRD10000	10000	203	40.7	ANSI 10" #150	Air/water	61.9	111.3	96.6	5,390

EGRD REFRIGERATED AIR DRYER SCHEMATIC DIAGRAM

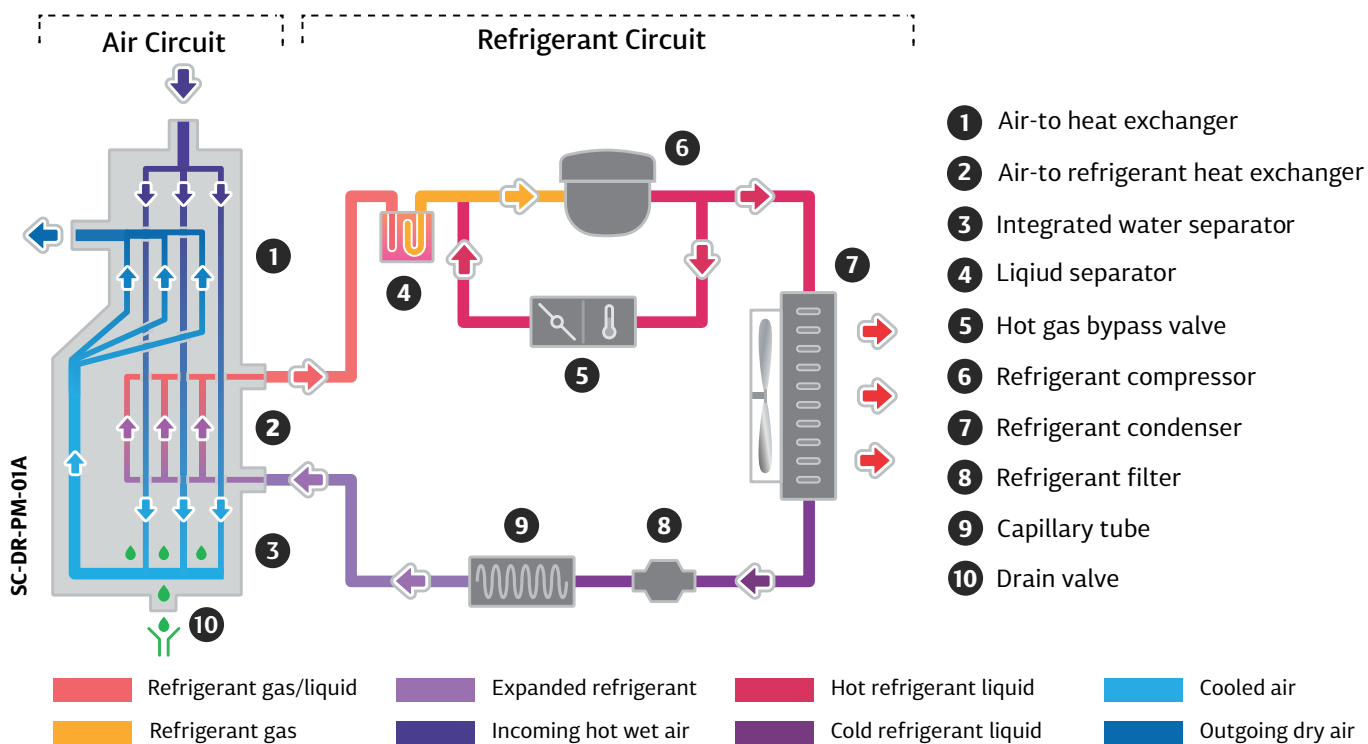

- Reference condition for inlet flow capacity:
 - Ambient temperature - 100 °F
 - Inlet compressed air temperature 100 °F
 - Inlet pressure - 100 psig
- See correction factor for sizing for conditions other than reference conditions.
- 575 range available on request.
- All data mentioned above is measured according to ISO 7183, with standard voltages, at 38-41 °F dew point.
- High pressure dryers and high ambient temperature dryers are available on request.
- Standard scope of supply includes only electronic drain valves up to EGRD500 & zero loss drains from EGRD600.
- Consult factory for watercooled dryers.

ENERGY SAVING CYCLING REFRIGERATED AIR DRYERS

ELGi's Energy Saving Cycling Refrigerated Air Dryers eliminates the moisture which makes it an ideal accessory that can be used for a wide range of applications.

FEATURES AND BENEFITS

- Hermetically sealed refrigeration compressor aids high energy efficiency.
- Automatic condensate drain removes condensate from the system with no air loss and minimal maintenance.
- Smart controller displays the pressure dew point temperature (°C or °F) and indicates if the dryer is running in energy saving mode (ECO).
- The integrated filters improve performance with less pressure drop and help reduce additional piping before and after the dryer for external filters.
- The aluminium plate type heat exchanger maximizes thermal exchange efficiency due to its high heat transfer surface area.



TECHNICAL SPECIFICATIONS

Model	Inlet flow capacity	Air pressure drop	Max. inlet pressure	Inlet/outlet size	Dimensions (inch)			Gross weight
	cfm	psi	psi	NPT	Length	Width	Height	lbs
AR 0100P	100	1.4	230	1 1/2"	25.5	26.7	50.3	196
AR 0125P	125	1.9	230	1 1/2"	25.5	26.7	50.3	209
AR 0140P	140	2.4	230	1 1/2"	25.5	26.7	50.3	221
AR 0175P	175	1.4	230	2"	32.6	33.7	59.3	392
AR 0200P	200	1.6	230	2"	32.6	33.7	59.3	406
AR 0250P	250	1.6	230	2"	28.7	32.6	69.4	428
AR 0350P	350	2.3	230	2"	28.7	32.6	69.4	534
AR 0425P	425	2.5	230	2"	28.7	32.6	69.4	558
AR 0550P	550	1.7	230	3"	31.4	45.2	68.5	650
AR 0700P	700	2.1	230	3"	31.4	45.2	68.5	683
AR 0900P	900	1.5	230	3"	34.6	51.7	70.4	906
AR 1100P	1100	1.9	230	3"	34.6	51.7	70.4	977
AR 1350P	1350	1.7	230	4"	39.1	62.1	77.8	1184
AR 1500P	1500	1.8	230	4"	39.1	62.1	77.8	1228
AR 2000P	2000	2.6	230	4"	42.4	70.7	81.7	1625
AR 2350P	2350	2.8	230	4"	42.4	70.7	81.7	1676
AR 2750P	2750	2.4	230	6"	41.8	90.5	79.6	2075
AR 3000P	3000	2.4	230	6"	41.8	90.5	79.6	2123
AR 3600P	3600	2.4	230	6"	60.9	88.5	83.2	2260
AR 4000P	4000	2.4	230	8"	60.9	88.5	83.2	2562
AR 5000P	5000	2.4	230	8"	60.9	100.3	85.5	3263

CYCLING REFRIGERATED AIR DRYER SCHEMATIC DIAGRAM

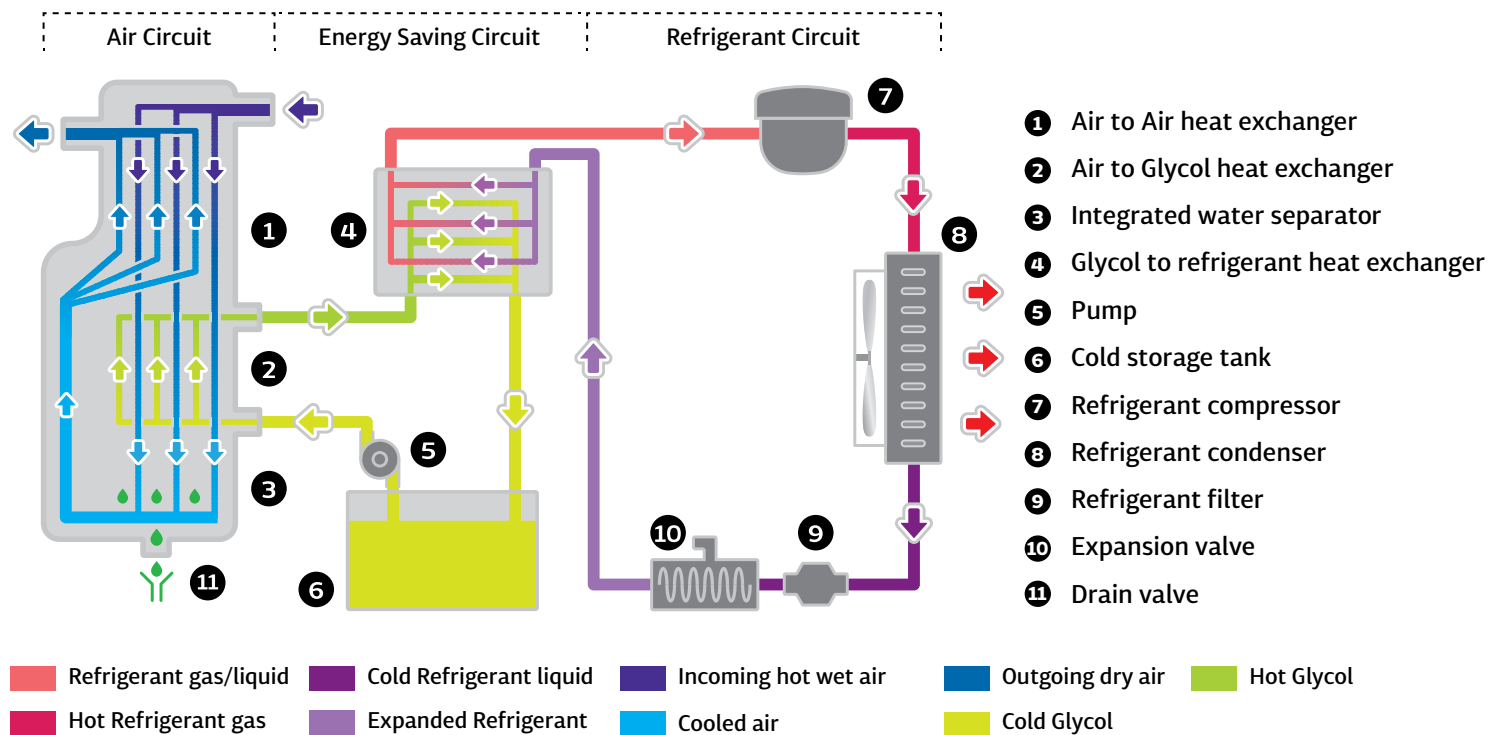

- All models are standard with R-134a refrigerant.
- Reference condition for Inlet flow capacity:
 1. Ambient temperature - 100° F
 2. Inlet compressed air temperature 100° F
 3. Inlet pressure - 100 psig
- All data mentioned above is measured for air cooled versions according to ISO 7183, with standard voltages, at 38 °F pressure dew point.
- Standard scope of supply includes mechanical level sensing drains.
- Variants also available for these Ph/V/Freq: 1/230/60 and 3/460/60.
- Integrated filters are standard for capacity up to 2350 cfm, delivered air quality at the outlet 1-4-1 as per ISO8573.
- The above indicated pressure drop is including the integrated filters for applicable models.
- Due to continuous engineering improvements, the specifications are subject to change without prior notice.

AIRMATE FILTERS

ELGI's Airmate Filter (AF) is suitable for all applications which require filtered air for reliable performance. AF series filters provide the customer with best-in-class filtration and the lowest pressure drop. The filters are manufactured in compliance with applicable international standards (ASME, CE, CRN) and designed according to international quality standards.

OVERALL VALUE PROPOSITION



Best-in-Class Performance



Best-in-Class Energy Efficiency



Best-in-Class Warranty



Technical data	Coalescing pre	Coalescing fine	Activated carbon
Filter type	P	F	C
Particle removal (micron)	1	0.1	-
Max. Oil carry over 3 (mg/m ³)	0.1	0.01	0.003
Min. Recommended temperature	38 °F		
Max. Recommended temperature	176 °F		122 °F
Initial dry pressure loss	1.1 psi	1.4 psi	1.1 psi
Initial wet pressure loss	1.4 psi	2.3 psi	-
Pressure loss for element change	10.1 psi		
Recommended replacement of elements (Whichever is earliest)	12 months or when the DP Gauge indicates red		6 months
Precede	Type F with type P		Type C with type P, F

- * Filter type C will not remove certain gases and is not recommended for medical air application usage without using suitable medical grade filter
- * Air inlet temperature should be 77° F for filtration of 0.003 mg/m³ quality oil in the air
- * Maximum oil carry over for pre and fine filters at 70° F

TECHNICAL SPECIFICATIONS

Model (P-F-C)	End connections*	Flow rate @7 barg (100 psig)	Product dimension (inch)					Net weight (dry condition)	Max. operating pressure
		scfm	H1	W	G	D	H2	lbs	psig
AF 0021	3/8"	21	8.4	3.5	1.4	0.7	7.5	2.3	290
AF 0041	1/2"	41	10.7	5	1.7	1.2	9.8	5.1	290
AF 0059	1/2"	59	11.9	5	1.7	1.2	10.9	4.4	290
AF 0074	1/2"	74	13.5	5	1.7	1.2	12.5	5.9	290
AF 0088	1"	88	14.5	5.5	1.7	1.2	13.1	7.3	290
AF 0132	1"	132	15.6	5.5	1.7	1.2	14.3	7.1	290
AF 0177	1 1/4"	177	18.6	5.5	1.7	1.2	17	10.5	290
AF 0235	1 1/4"	235	22.2	5.5	1.7	1.2	20.5	12.3	290
AF 0294	1 1/2"	294	20.1	5.9	1.7	0.9	18.2	12	290
AF 0420	1 1/2"	420	27.4	5.9	1.7	0.9	25.5	15.1	290
AF 0520	1 1/2"	520	33.5	5.9	1.7	0.9	31.6	17.6	290
AF 0620	1 1/2"	620	38.4	5.9	1.7	0.9	36.5	20.2	290
AF 0912	2 1/2"	912	27.8	9.4	1.7	0.9	25.9	34.8	290
AF 1177	3"	1177	33.9	9.4	1.7	0.9	32	40.7	290
AF 1589	3"	1589	38.3	9.4	1.7	0.9	36.9	45.3	290
AF 2001	DN100 / 4"	2001	34.2	14.1	1.7	1.1	31.8	63.6	150
AF 3178	DN100 / 4"	3178	42.1	14.1	1.7	1.1	39.7	74.4	150
AF 6475	DN200 / 8"	6475	62.1	30.9	-	-	-	825	203

- * NPT & BSP end connections available, for flange filters ANSI/DIN standard connections available.
- Differential pressure gauge and internal float drain are standard only for pre and fine filters.
- For any product selection outside standard catalogue, contact sales.
- For flow rate other than 7 barg (100 psig), use correction factor from below table.

AIRMATE FILTERS CORRECTION FACTOR

For a flow rate other than 7 barg (100 psig), use the correction factor below.

Inlet air pressure - F1	psig	1	3	5	7	9	11	13	15	16	18	20
Correction factor		0.5	0.7	0.8	1	1.1	1.2	1.3	1.4	1.5	1.5	1.6

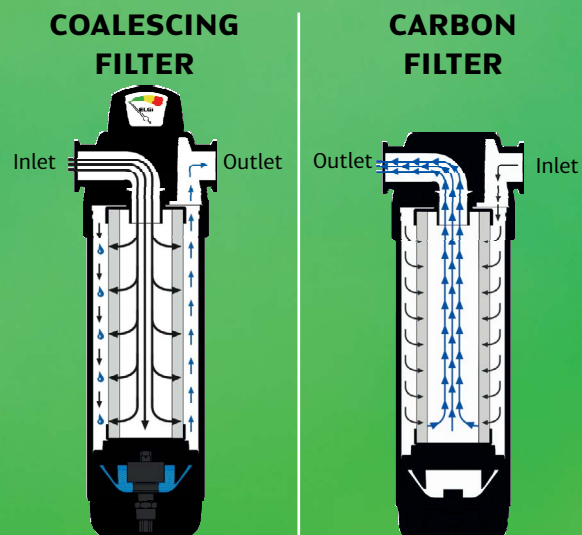
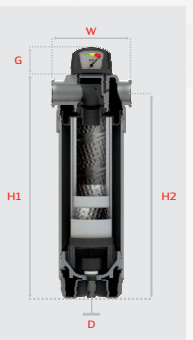

ADD-ON OPTIONS

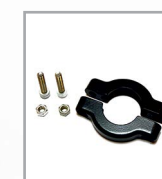

CLAMP

Connect two filters easily without any pipes.



WALL MOUNTING KIT

Wall mounting kits are available to connect the filters to the wall easily.



ZERO LOSS DRAIN

Only condensate is drained with an external level sensing drain, and there is no air loss (energy saving). Both mechanical and electronic drain options are available.

AIRMATE DRAIN VALVES

“Zero Loss Advantage”

Compressed air condenses moisture in dryers, aftercoolers, and air receivers. This condensate needs to be removed frequently. This process is done by the drain valves. In ordinary drains, there is always a loss of compressed air.

Most of the condensate drains have a 4 mm orifice. This 4 mm orifice bleeds about 34 cfm, which is the equivalent of 6.5 kW of power. ELGi Airmate drains work on the principle of zero air loss and do not bleed your compressed air, consequently saving energy.

ELZ Drain Valve

The condensate sensing type automatic drain valve is the latest advancement in drain valve technology. Instead of operating through a cycle timer, these valves sense the condensate level for activation, ensuring absolutely no loss of compressed air and hence enormous energy saving. These drain valves are highly efficient and reliable. They can be fitted directly on the equipment simply by replacing the manual drains.

- The electronic level control ensures proper draining of condensate and avoids the unnecessary loss of air.
- All the functions of the valve are accurately indicated by the LED display.
- Test switch (or) manual drain allows function test at any time.
- Intelligent Controller detects valve, probe failure and acts accordingly.
- Noise-free, as air is not discharged.

Model	Max. compressor capacity	No. of inlet ports	Inlet & outlet port size	Dimensions (inch)			Max. working pressure
	scfm	Nos	inch	L	B	H	psi
EZL 10	350	1	1/2" x 1/4"	4.8	3.6	2.9	232
EZL 100	3500	3	1/2" x 1/4"	3.5	7	4.4	232



OIL-WATER SEPERATOR

When the air is compressed through the compressor, it results in condensate and compressed air: condensate is a mix of water, oil, and dust particles. If not appropriately treated and released into the environment, this condensate can have detrimental effects on the environment. Regulatory bodies for effluent treatment recommend that this condensate be cleansed before releasing it to sewage disposal.

ELGi EOS series is specifically designed to maintain less than 10 ppm of oil in the condensate before allowing the fluid to pass on to the environment. The multi-level separation process with super-efficient fiber adsorbent and activated carbon ensures the contaminant levels are kept well within the statutory requirements.

Large compressor systems might require two or more oil/water separators to be installed to match the total compressor capacity of an installation. To connect the oil/water separators and ensure an even condensate distribution into the oil/water separators, you require the Distributor. The Distributor has two 1" condensate inlets and six 1/2" outlets with integrated ball valves, allowing you to connect two and up to six oil/water separators.

Distributor



Mini Distributor



Multi-Inlet Adapter

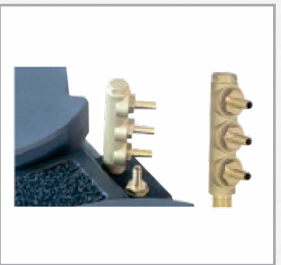

TECHNICAL SPECIFICATIONS

Model	Maximum compressor capacity	Maximum oil adsorption capacity	No. of inlet / outlet port	Inlet hose barb (inner dia.)	Outlet hose barb (inner dia.)	Package dimensions (inch)			Gross weight (empty)
	scfm	Gallon	Nos	inch		L	B	H	lbs
EOS - 7	70	0.5	1	0.4	0.5	10	9	9.9	7
EOS - 13	130	0.8	1	0.4	0.5	15.6	9.5	15.2	13
EOS - 18	175	1.3	1	0.4	1	22.8	7.5	24	22
EOS - 35	350	2.6	1	0.4	1	25.6	9.5	29.5	37
EOS - 70	750	3.9	1	0.4	1	30.7	12	35.4	66
EOS - 110	1250	7.9	1	0.4	1	38.1	15	35.4	95
EOS - 210	2500	13.2	1	0.4	1	45.7	18.9	41	163

UPTIME™ MANAGER

In multiple compressor installations, it isn't easy to choose the correct combination of compressors manually. This results in wastage of 20 - 60% of the power. To cut such operating costs, we bring in the Uptime Manager Supply-Side Controller.

The controller can manage any number of positive displacement compressors including compressors of different capacities, different types (fixed speed, variable speed, and variable capacity), and in any combination or configuration. Through advanced control functionality and universal connectivity, the Uptime Manager will work with your existing compressors, from ELGi or any manufacturer, to improve operating efficiency and reduce energy costs. Here's how the Uptime Manager controller delivers a unique combination of efficiency and reliability:

- Operate compressors only as needed, bringing standby compressors online incrementally during periods of increased demand.
- Dynamically match the most energy-efficient compressor or combination of compressors with compressed air demand.
- Manage the compressed air system at your minimum required pressure without compromising the reliability of your compressed air supply.

UPTIME MANAGER BRINGS ENERGY EFFICIENCY

Running a compressor in standby mode (unloaded) to ensure maximum capacity when needed uses approximately 25% or more of the energy required to run that same compressor fully loaded. Systems with multiple compressors of varying sizes, types, and configurations further complicate manual coordination and maintaining the correct compressor settings. The larger the system, the more will be the unproductive energy cost!

The Uptime Manager eliminates the complexity of compressor control coordination and increases energy efficiency. Only the specific compressors operate at a given time. Other compressors used for normal operations with manual control will be kept offline and shall be available during emergency requirements or during primary equipment breakdown. This ability to tap existing resources to maintain system operation even in emergencies makes the system more reliable. In addition to optimizing energy usage, efficient compressor utilization reduces costs due to less downtime.

MANAGE YOUR BATTERY OF AIR COMPRESSORS EFFICIENTLY

The primary functions of Energy Control Mode in Uptime Manager are:

- Match compressed air supply to compressed air demand dynamically.
- Utilize the most energy-efficient combination of air compressors to satisfy demand.
- Manage multiple compressors at the minimum required pressure band.

Connectivity, Communication, and Control at the Heart of Your Air System

ELGi's Uptime Manager is one air system control solution that quickly pays for itself without compromising any of your previous capital investments on the compressor or air system.

SINGLE-POINT CONTROL	PRIORITY COMPRESSOR SELECTION	REAL-TIME SYSTEM SCHEDULING	CONTROLLED OPERATIONS	SYSTEM PREFILL
Manage multiple compressors to one optimal control band or target. Single controller with programmable logic controls all compressors in a compressor house or common header.	Minimize energy use by programming units or groups for optimum utilization and/or operations planning including equalized usage. For example, you can now prioritize more efficient compressors as lead compressors or VFD-driven compressors for trim requirements.	Configure control features, including system standby and system prefill on a real-time schedule.	Fully adjustable time parameters help implement smooth, controlled schedule changes from one target pressure level to another.	Will prevent all compressors from starting simultaneously after the system has been shut down for a while.

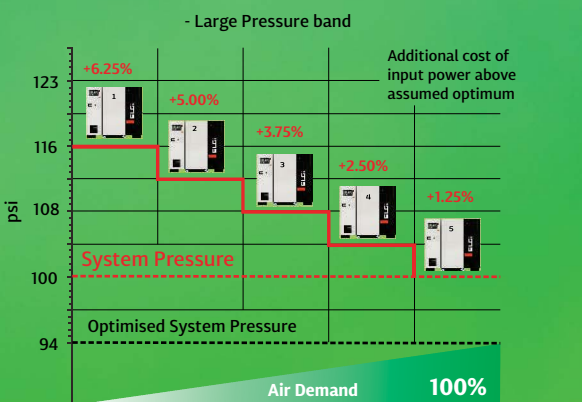
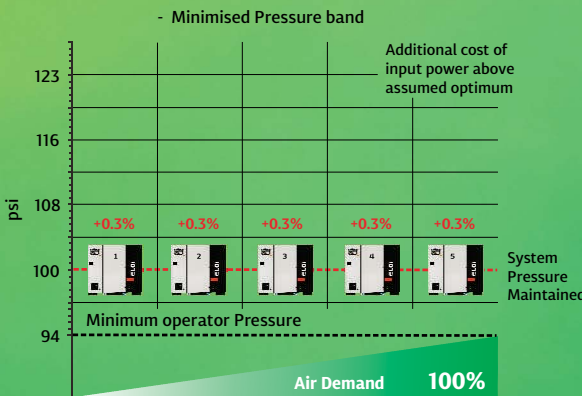

UPTIME Manager	UM4	UM12	UM24
Maximum number of Compressor:			
4 no.	✓	✓	✓
12 no.		✓	✓
24 no.			✓
Type of Compressor regulation:			
Fixed Speed Compressor	✓	✓	✓
Variable Frequency Compressor		✓	✓
Variable Displacement Compressor		✓	✓
Operating Mode:			
Timer Rotation	✓	✓	✓
Equal Running Hours	✓	✓	✓
FIFO	✓		
Energy Control		✓	✓
UPTIME Manager Functions:			
Priority Selection	✓	✓	✓
System Pre-fill	✓	✓	✓
Pressure Balancing (for multiple Compressor rooms)			✓
Zone Control (for multiple compressor rooms)			✓
Inbuilt Real Time Clock:			
Schedule to Start/Stop System	✓	✓	✓
Pressure Band Change (through table technology)	✓	✓	✓
Compressor Priority Change (through table technology)	✓	✓	✓
Operating Mode Change (through table technology)	✓	✓	✓

Note: For helping you understand the right solution for your compress or house contact sales.

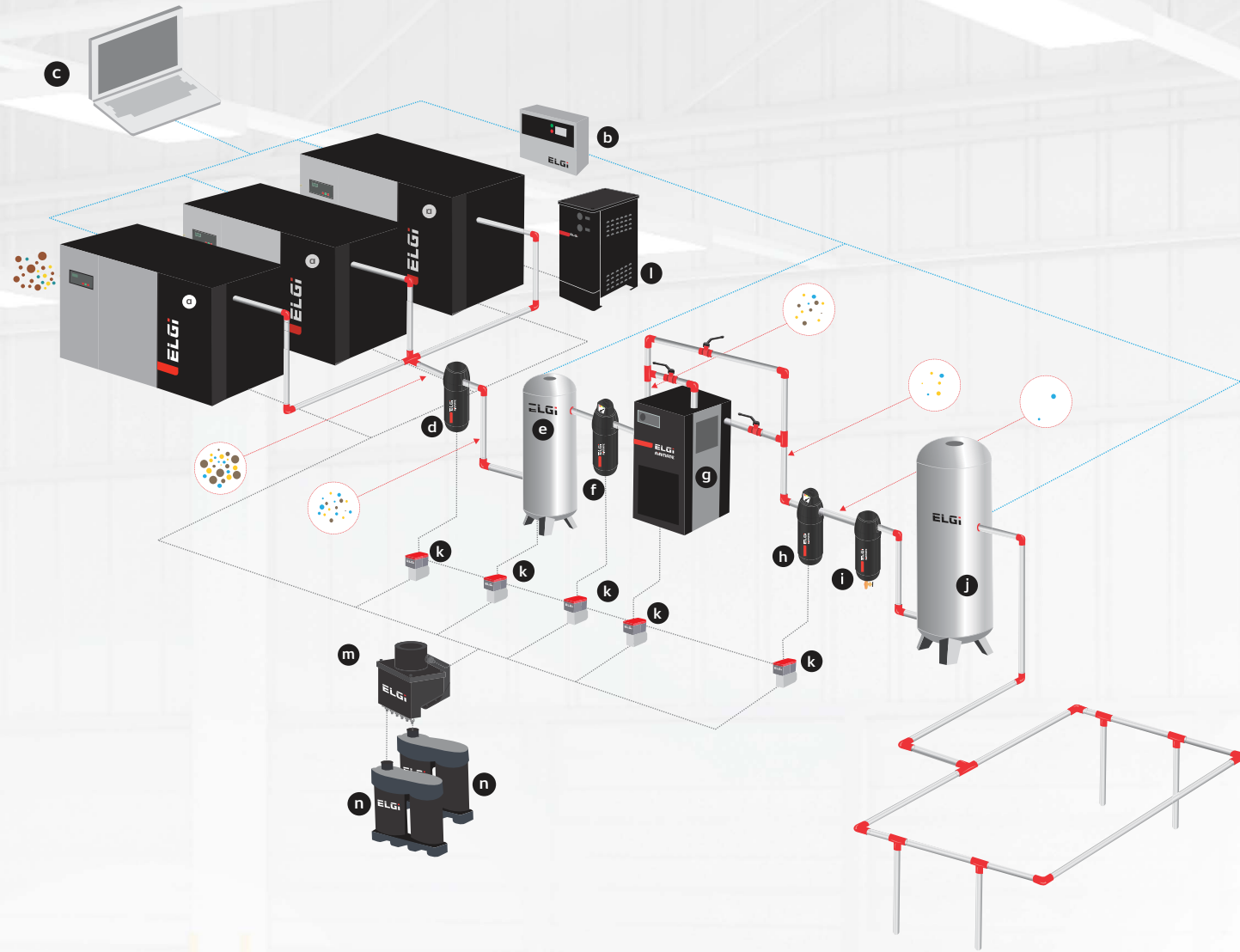

TYPICAL COMPRESSED AIR SUPPLY SYSTEM

- | | |
|------------------------------------|-------------------------------------|
| A. EG Series Compressor | H. Airmate Filter - Fine Coalescing |
| B. UPTIME Manager | I. Airmate Filter - Carbon |
| C. Remote-Central Control | J. Airmate Receiver Dry |
| D. Moisture Separator | K. Drain Valve |
| E. Airmate Receiver wet | L. Heat Recovery System |
| F. Airmate Filter - Pre Coalescing | M. MAXI Distributor |
| G. EGRD Refrigerant Dryer | N. EOS - Oil Water Separator |

- DUST PARTICLES
- OIL
- MOISTURE

ELGi

Always Better.

Elgi Equipments Limited is a global air compressor manufacturer with a broad line of innovative and technologically superior compressed air systems.

ELGi has consistently worked towards ensuring that its customers achieve their productivity goals while keeping the cost of ownership low. ELGi offers

a complete range of compressed air solutions from oil lubricated, oil free rotary screw compressors, and oil lubricated compressors, to dryers, filters, and downstream accessories.

The company's portfolio of over 400 products has found wide application across industries.

60+

Years of Customer-Centric Innovation

2 Mn+

Installations Worldwide

120+

Countries and Counting



DEMING PRIZE 2019

ELGi is the first globally established industrial air compressor manufacturer to be awarded the Deming Prize for Excellence in Total Quality Management.

ELGi[®]
Always Better.

